

H. E. NICKERSON.
Lathes.

No. 133,593.

Patented Dec. 3, 1872.

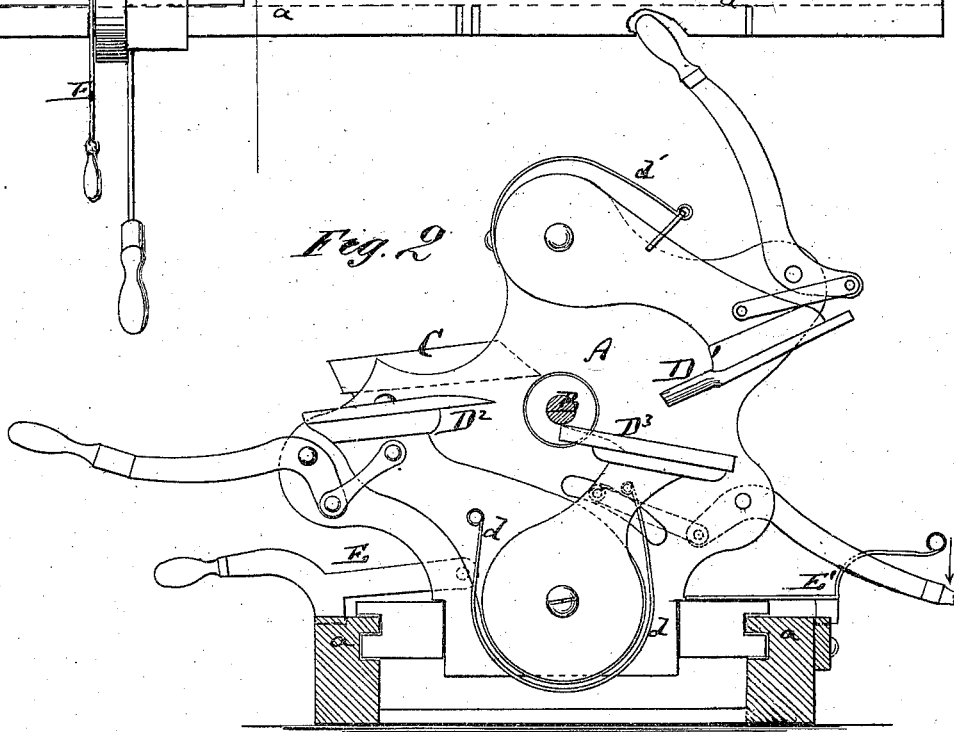
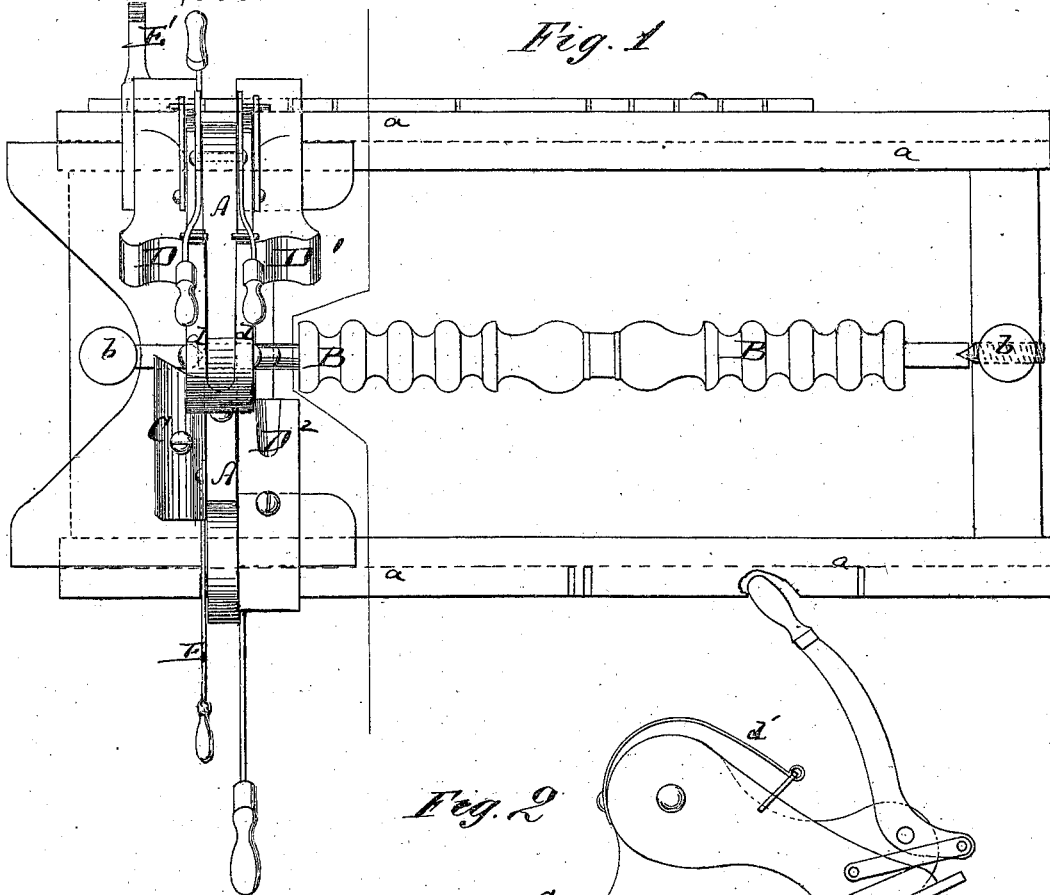

Witnesses:

A. W. Hampwick
C. Sedgwick

Inventor:

H. E. Nickerson

PER

Wm. L. C.
Attorneys.

UNITED STATES PATENT OFFICE.

HEZEKIAH E. NICKERSON, OF ATCHISON, KANSAS.

IMPROVEMENT IN LATHES.

Specification forming part of Letters Patent No. 133,593, dated December 3, 1872.

To all whom it may concern:

Be it known that I, HEZEKIAH E. NICKERSON, of Atchison, in the county of Atchison and State of Kansas, have invented a new and Improved Molding-Lathe, of which the following is a specification:

Figure 1 is a top view, and Fig. 2 a vertical transverse section, of my improved molding-lathe.

Similar letters of reference indicate corresponding parts.

My invention relates to an arrangement of levers, knives, and springs, forming an improved attachment to a wood-turning lathe for turning balusters, bedstead-posts, and other analogous articles, as will be hereinafter more fully described.

In the accompanying drawing, the letter A represents a carriage sliding on two rails, *a a*, which constitute the top of the lathe-frame. *b b* are the two head and tail stocks, as on a common turning-lathe. The wood B to be turned is held in the two head-stocks in the ordinary manner, and fits through a hole in the carriage. To the carriage is rigidly affixed a knife, C, for cutting the wood down to the requisite diameter. D D¹ D² D³ are knives pivoted to the carriage, and provided with handles, respectively, and with springs *d d*. These springs hold the pivoted knives away from the wood. There may be but one pivoted knife on the carriage A, or any suitable

larger number, according to the kinds of moldings to be turned on the wood, the cutting edges of the several knives being shaped in accordance with the moldings to be cut. To the carriage A is also pivoted a catch, E, to lock it in notches, which are cut into one of the rails *a*; or there may be two catches, E and E', one on each side of the carriage, and both rails *a* be notched, or else the notches may be cut into strips fastened to the rails.

As the carriage is fed along the rails *a* it is locked by the catch or catches in the successive notches, and whenever it is so locked one of the pivoted knives is swung against the wood to impart to it the desired shape at that place. In this manner the wood can be quickly shaped with a proper degree of smoothness, and very exact, and a great saving effected on the ordinary method of turning.

Having thus described my invention, I claim as new and desire to secure by Letters Patent—

The knives D² D³, pivoted to the carriage A at the same point, connected by the single spring *d*, and provided with their elbow-levers, all constructed, arranged, and operating as shown and described, for the purpose described.

HEZEKIAH E. NICKERSON.

Witnesses:

J. H. TALBOTT,
JOHN V. JILLICH.